

# TR-250 Automatic Rice Husker Operating Manual



This unit is equipped with a motor-driven husker roll unit.

Do not place your fingers in the sample inlet. Finger placed in the sample inlet may be caught in the husker roller and injuries may result.

## ● About the TR-250

This unit is an automatic rice husker for making brown rice samples used with electric resistance type grain moisture meters including the PB-1D2, SP-1D3 and Riceter f.

Only the brown rice necessary for moisture measurement will be collected, while chaff and brown rice are separated at hulling, enabling the TR-250 to help improve moisture measurement efficiency at rice centers, country elevators and other agricultural facilities where multi-point moisture measurement is required.

## ● Specifications

Hulling capacity : approximately 20 grams / 60 seconds

Applicable moisture range : 12 to 18%

Safety device : overload automatic stop device

Power supply : 100 V AC (50/60 Hz)

Dimensions : 205 (W) x 130 (D) x 130 (H) mm

Mass : approximately 1.8 kg

## ● Part Names

### 《 Main unit 》

Paddy inlet



\* Be careful not to put your fingers in the sample inlet. The inner roller in the sample unit can catch fingers and severely injure them.

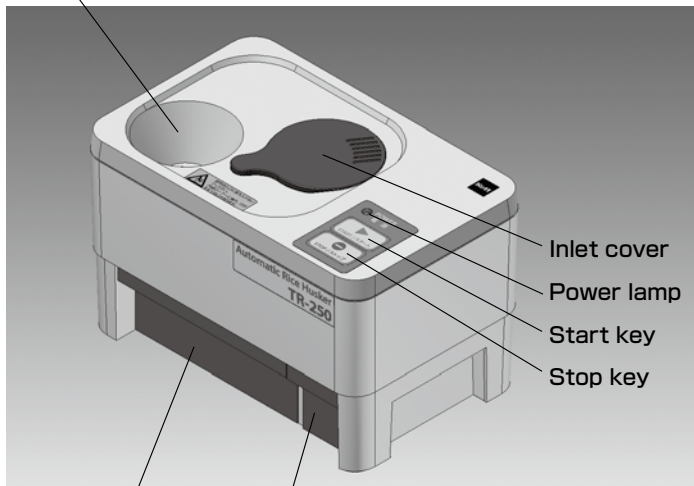

Chaff tray

Brown rice tray

Inlet cover

Power lamp

Start key

Stop key

### 《 Accessories 》

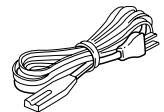

Power cord

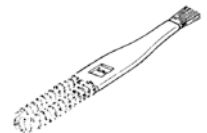

Brush

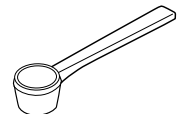

Measuring spoon

## ● How to Use

- ① Plug the power cord into the socket on the rear panel of the main unit; connect the power cord to a 100V AC power supply; the power lamp will light up.

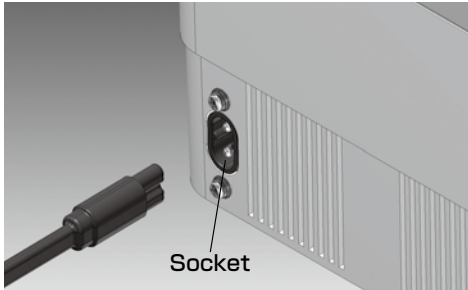

- ② Open the inlet cover; scoop paddy with the supplied measuring spoon; put the paddy in the paddy inlet.

\* The maximum loadable amount of paddy at one time is approximately 20 grams, which will almost fill the inlet section. Forcing in too much paddy will jam the unit and it may not work.

- ③ Close the inlet cover and press the [Start] key. The motor starts and hulling rice starts.

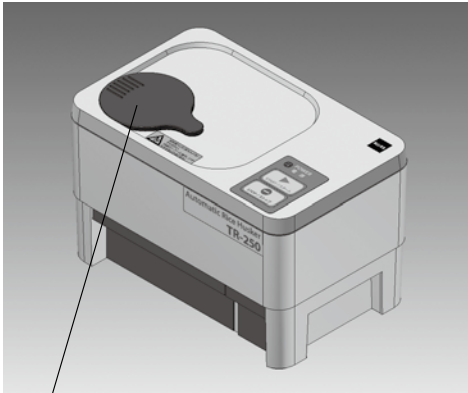

\* Keep the inlet cover closed while hulling. If the cover is open, paddy may bounce out.

- ④ The unit creates a rattling sound inside the unit while hulling.

Chaff and thin grain are collected in the chaff tray; a brown rice sample is collected in the brown rice tray.

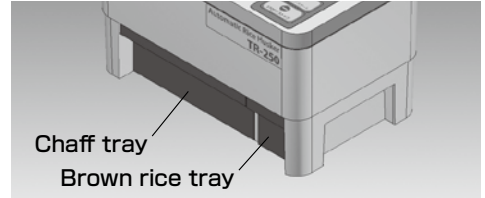

- ⑤ When the inside of the unit is empty, the rattling sound stops. Only the sound of the motor rotation will be heard. Press the [Stop] key 15 seconds after that to stop the operation.

\* If the [Stop] key is pressed immediately after the hulling sound disappears, paddy may remain inside the unit.

\* If the main unit is jammed with paddy or a foreign object such as a pebble enters the unit during hulling, the safety protection function will automatically stop the motor. When the protection function is activated and the operation stops in the middle of hulling, pressing the [Start] key again enables resuming the operation.

If pressing the [Start] key again does not restart the operation, insert a slotted screwdriver into the circular hole on the side of the main unit, rotate the driver a half turn clockwise and press the [Start] key. Operation can then be resumed.

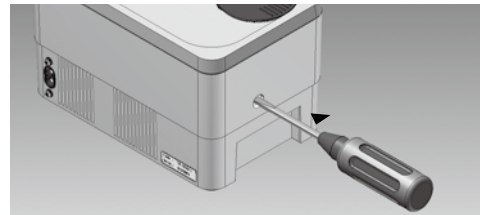

\* If a foreign object is caught inside the main unit, disassembling the unit is required to remove the object.

Refer to "● How to Replace Husker Roll Unit" on the next page.

## ● How to Replace Husker Roll Unit

This unit is equipped with a Husker Roll Unit.

The roller inside the unit wears down through prolonged use.

When the roller wears down too much, the hulling capacity decreases and foreign objects are more likely to be caught in the roller, resulting in machine problems such as motor malfunctions.

When this problem appears, replace the Husker Roll Unit in the following manner:

- ① Unplug the power cord from the main unit.
- ② Turn over the main unit and remove the 3 screws.

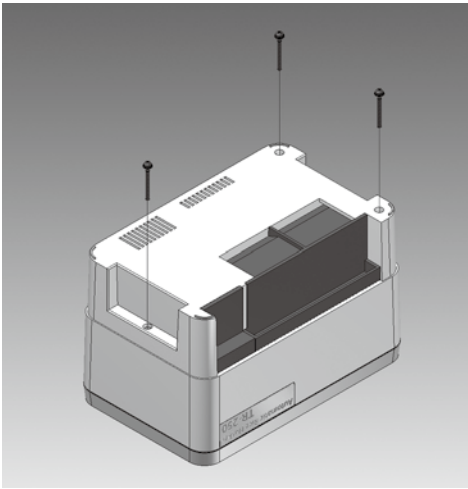

- ③ Turn over the main unit again, remove the upper case portion upward and remove the Husker Roll Unit.

\* If chaff remains inside the unit, clean the inside of the unit.

- ④ Embed a new Husker Roll Unit in the main unit. Ensure that the roll unit gear is securely engaged with the motor gear.

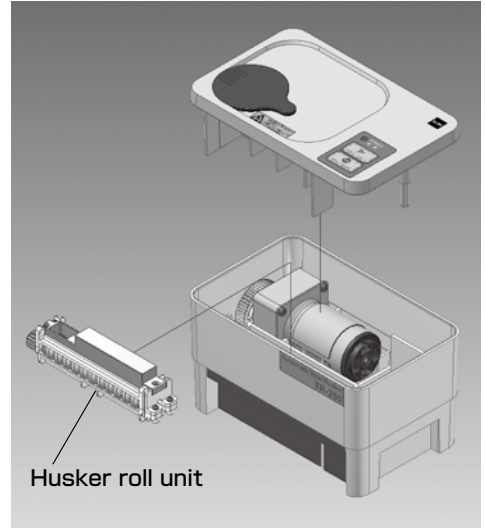

- ⑤ Replace the removed upper case portion and firmly set the upper case portion in the bottom case portion. Be careful not to catch the cables between the case portions.
- ⑥ Turn over the main unit while holding the upper case portion firmly and secure the upper case to the main unit with the 3 screws.
- ⑦ Turn over the main unit again, plug the power cord into the socket on the rear panel of the main unit and press the [Start] key.
- ⑧ The replacement operation is completed when the operation sound is normal.

## Cautions

- Reproducing part or all of this manual without permission is prohibited.
- The contents of this manual are subject to change without notice.
- The appearances, screens and other parts of the product and accessories displayed in this manual may differ from the actual ones, but the operations and functions are not affected.
- All efforts have been made to ensure the contents of this manual are accurate. However, if you notice any items in this manual to be unclear, incorrect, omitted or have any other problems, please contact us.
- Be aware that we are not liable for any results from operations according to this manual regardless of the items above.